



# AI Data Center Opportunity

August 2025



*Electrify Our World™*

This presentation contains forward-looking statements and information, including statements and information about Navitas' expectations for the growth of power demands of AI data centers, and the expected effects of this growth on demand for gallium nitride (GaN) and silicon carbide (SiC) based power semiconductor products in AI data center applications. These statements and information are subject to numerous risks and uncertainties that could cause actual events to differ materially from those described in this presentation.

Forward-looking statements and information generally can be identified by our use of words such as “expected,” “may,” “will,” “should,” “could,” “seek,” “intend,” “plan,” “forecast,” “anticipate,” “estimate,” or other similar expressions, graphical representations of expected technology and product development trajectories of end-customers and other industry participants, and estimates of market growth and related financial information.

These statements reflect Navitas' current views with respect to future events and are based on information available as of the date hereof. Readers are cautioned not to place undue reliance on these forward-looking statements. Actual results may differ as a result of factors discussed in the “Risk Factors” section of our most recent Form 10-K and Form 10-Q and other filings with the Securities and Exchange Commission and other public disclosures.

This presentation does not constitute an offer to sell or the solicitation of an offer to buy any securities. Past performance is not indicative of future results. The company undertakes no obligation to publicly update or revise any forward-looking statements.

# Only Pure-Play Next-Gen Power Semi Player



2014

Founded



Only  
GaN + SiC  
w/o Si power



>300

Mpcs  
shipped



700%

growth &  
Deloitte Fast  
500 (3 yrs)



+300

Patents issued  
or pending



\$160M+

Cash held with  
no debt



## Focus Markets



AI Data Center



New Energy



Mobile/Consumer

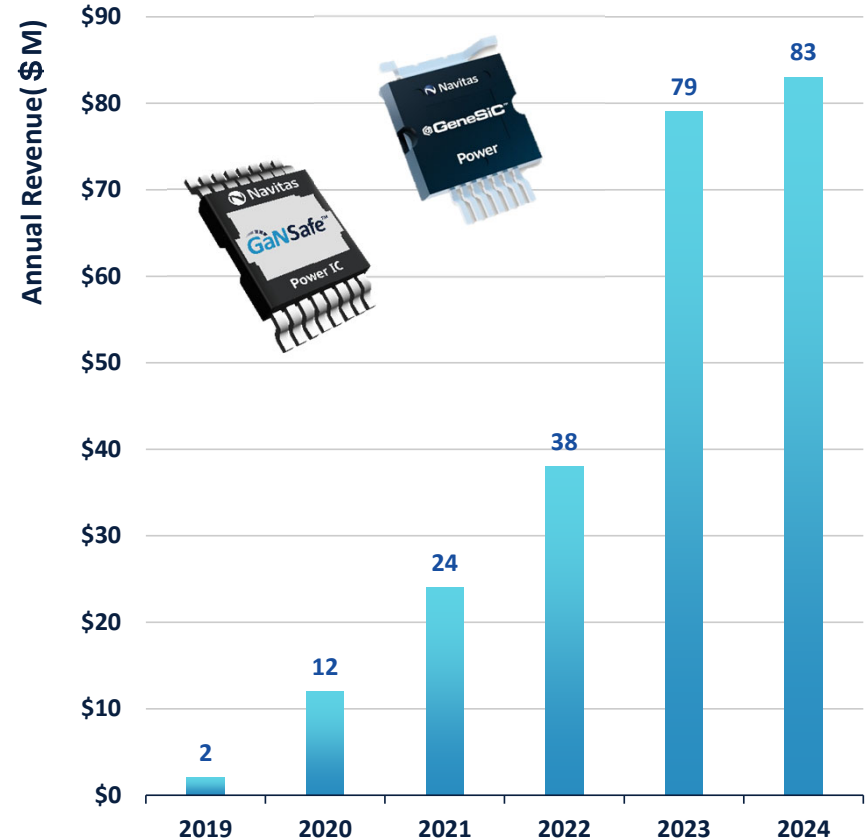



*GaN and SiC replace Silicon to make electricity more energy efficient, faster charging, more powerful and to miniaturize electrical systems.*



Up to <b>20x</b> Faster Switching	Up to <b>3x</b> Smaller &	Up to <b>40%</b> Energy	Up to <b>3x</b> Higher	Up to <b>3x</b> Faster	Up to <b>25%</b> Lower System Cost <sup>(1)</sup>
---	---------------------------------	-------------------------------	------------------------------	------------------------------	---



**GaN and SiC Replacing Si in Next-Gen Power Applications**

**Notes:**

1. Statistical data is based on Navitas estimates of GaN-based systems compared to Si-based estimates in the 2024-2025 timeframe. Based on Navitas measurements of select GaN-based mobile wall chargers compared to Si-based chargers with similar output power, incl. 2019 study of 65W fast chargers, 2022 customer statement re 2.7 kW data center AC-DC
2. Navitas estimates based on customer feedback as the expected system cost saving overtime as of April 2023

# NVTS Enabled GaN Mobile Charger Market

*Up to 3x faster charging your phone, tablet or notebook ... in half the size & weight!*

*More than doubling revenue annually over last five years (mobile & beyond)*



- 400+** GaN Chargers In Mass Production
- Top 10** smartphone & notebook OEMs
- 180+** GaN Chargers In Development
- >250M GaN** shipped in production
- <100ppb** field failure rate

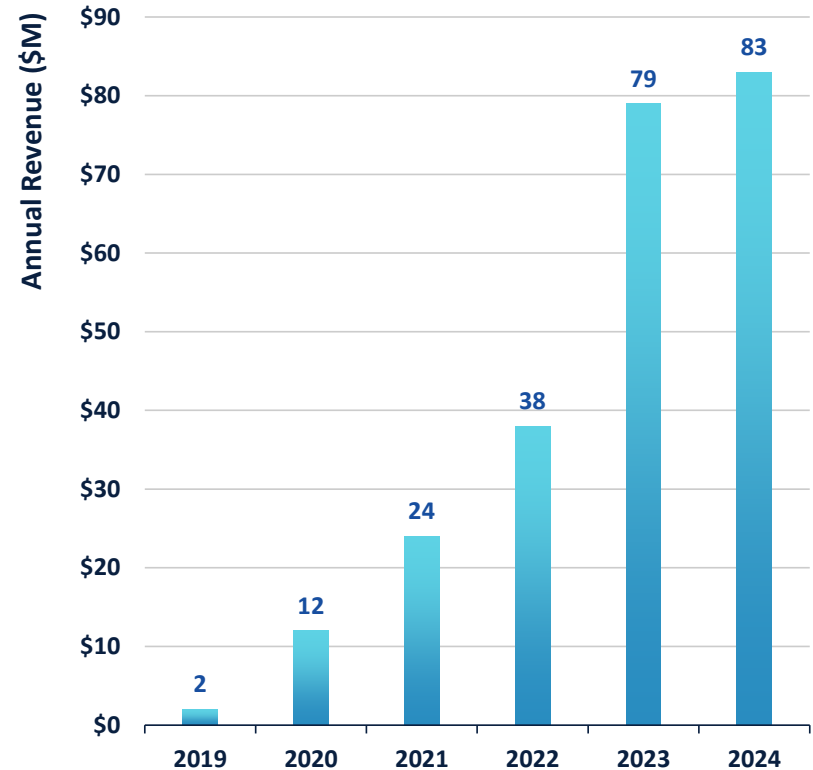

## AI is Driving Dramatic Increase in Power Demands

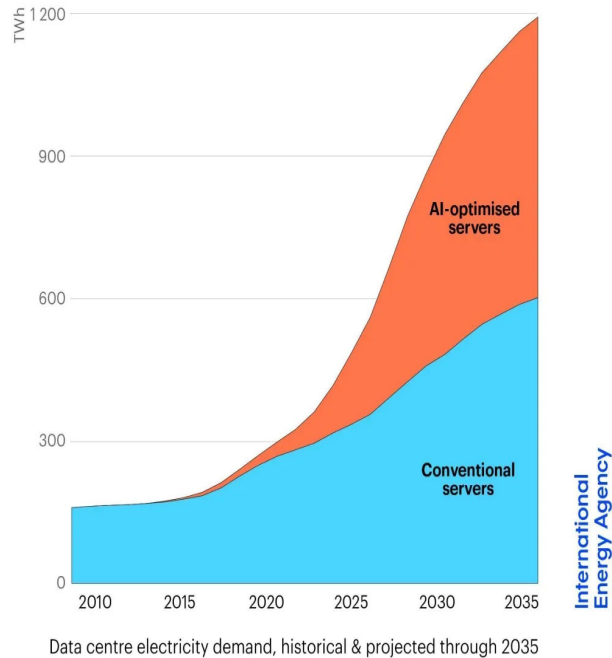

## Demanding a 100x increase in Server Rack Power

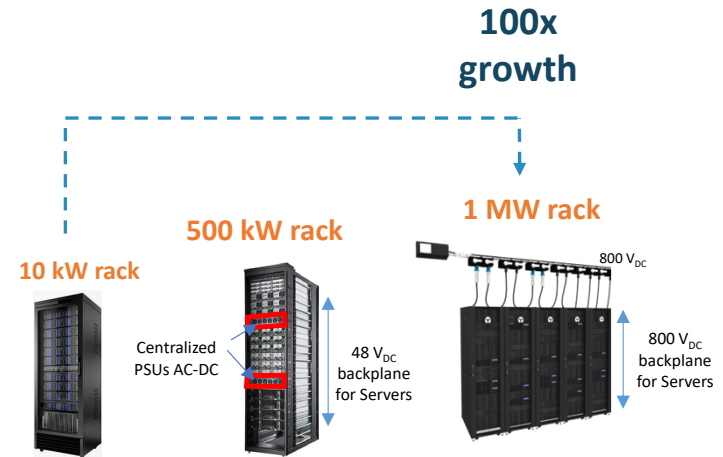

“Server Racks” are fundamental building blocks of data centers; 1MW server rack targeted by [NVIDIA](#).

<https://developer.nvidia.com/blog/nvidia-800-v-hvdc-architecture-will-power-the-next-generation-of-ai-factories/>

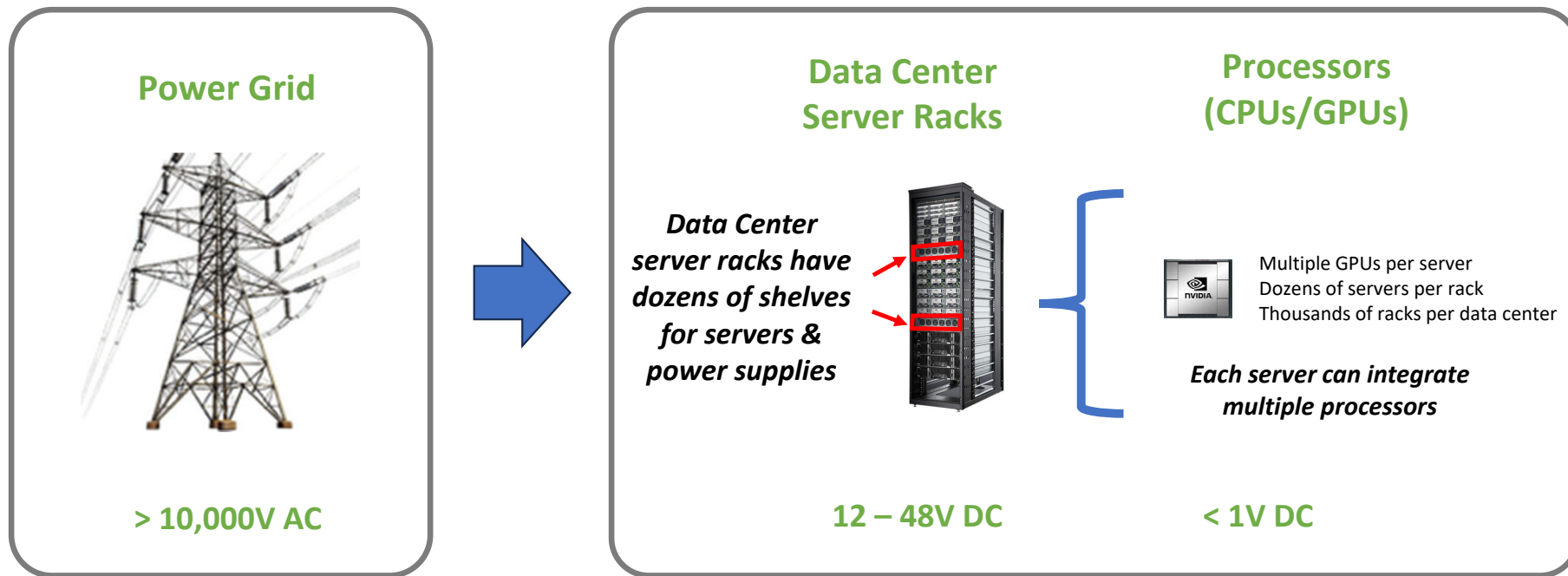

*Power supplies (based on power semiconductors) have the difficult challenge to convert **Grid** power to **GPU** power ... with highest **energy efficiency** (otherwise wasting energy as heat) & highest **power density** possible (to fit within server racks).*

# 800V Data Centers Are The Future

## Traditional 12V Data Centers

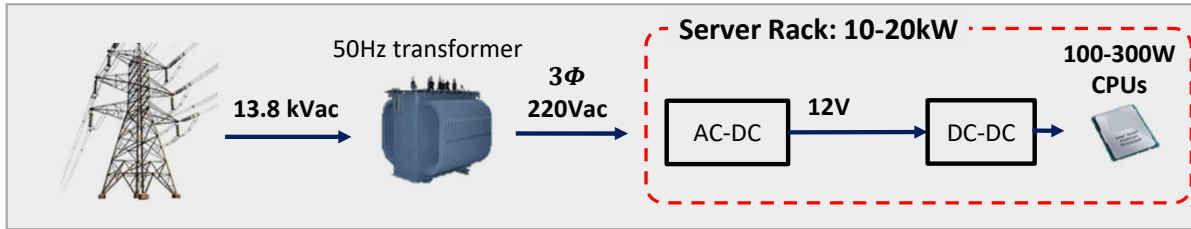

- 70-80% total energy efficiency
- 100% Si-based power systems
- Limited / no GaN or SiC use today

## Today's AI 48V Data Centers

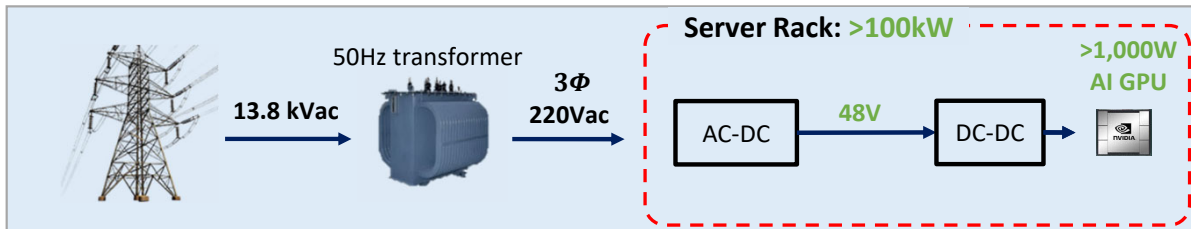

- 80-90% total energy efficiency
- 2030 power semi TAM: \$0.5B/yr
- Moderate GaN / SiC opportunity

## Future AI 800V Data Centers

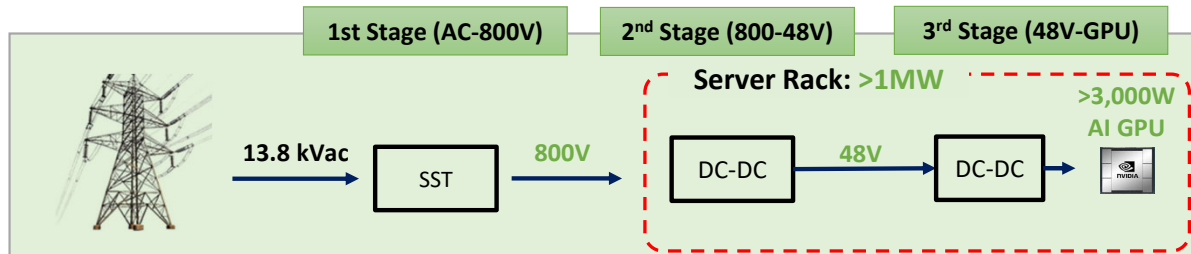

- Target >90% total energy efficiency
- 2030 power semi TAM: \$2.6B/yr
- Significant GaN / SiC opportunity

# Navitas: GaN/SiC Strength Across the Board

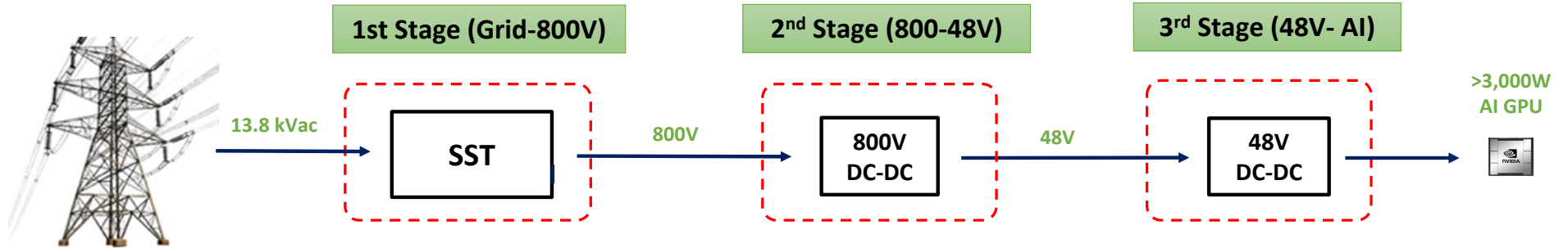

Grid

Suppliers	Ultra-High Voltage (UHV) SiC	High Voltage GaN / SiC	Mid-Voltage GaN
<b>Navitas</b>	<ul style="list-style-type: none"> <li>- Highest voltage (2.3 - 6.5kV)</li> <li>- Highest efficiency (up to 20% lower Rsp)</li> <li>- Highest reliability (epoxy SiCPak, AEC Plus)</li> </ul>	<ul style="list-style-type: none"> <li>- Most integrated / protected GaN (GaNSafe)</li> <li>- Highest reliability SiC (AEC Plus)</li> <li>- Optimized digital isolators</li> </ul>	<ul style="list-style-type: none"> <li>- High efficiency with proprietary pkg</li> <li>- Dual sourced (no IP risks)</li> </ul>
<b>Infineon</b>	<ul style="list-style-type: none"> <li>- High voltage (2.3 - 3.3kV)</li> </ul>	<ul style="list-style-type: none"> <li>- Competitive GaN</li> <li>- Competitive SiC</li> </ul>	<ul style="list-style-type: none"> <li>- High efficiency with proprietary pkg</li> <li>- Dual sourced (no IP risks)</li> </ul>
<b>ST, Rohm</b>	<ul style="list-style-type: none"> <li>- Limited voltages (<math>\leq 1.7kV</math>)</li> </ul>	<ul style="list-style-type: none"> <li>- Competitive SiC</li> <li>- Limited GaN</li> </ul>	<ul style="list-style-type: none"> <li>- No GaN</li> </ul>
<b>TI</b>	<ul style="list-style-type: none"> <li>- No SiC</li> </ul>	<ul style="list-style-type: none"> <li>- No SiC</li> <li>- Limited GaN</li> </ul>	<ul style="list-style-type: none"> <li>- Limited GaN</li> </ul>
<b>MPS</b>	<ul style="list-style-type: none"> <li>- No SiC</li> </ul>	<ul style="list-style-type: none"> <li>- No SiC</li> <li>- No GaN</li> </ul>	<ul style="list-style-type: none"> <li>- No GaN</li> </ul>

# 800V Data Center Target Customers

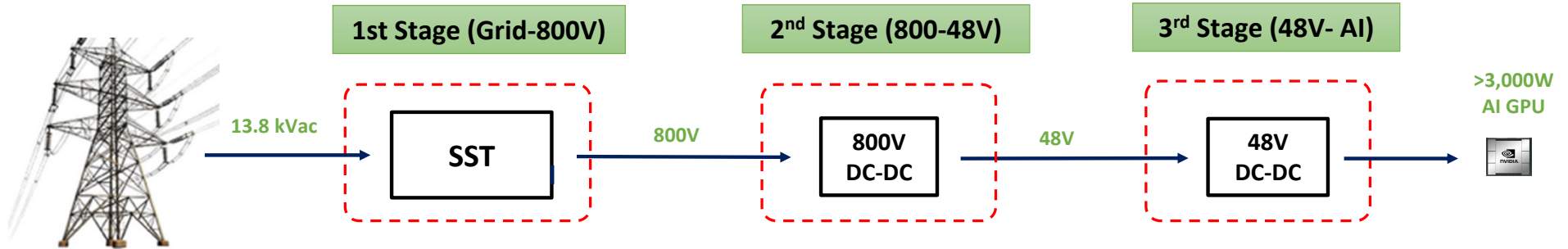

Grid



# GaN / SiC Opportunity for 800V Data Centers<sup>(1)</sup>

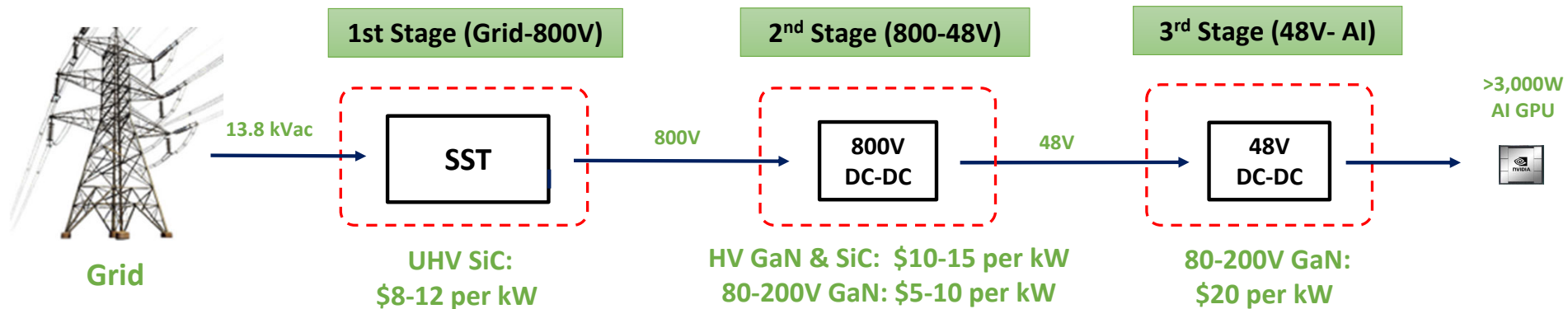

800V Data Centers	2025	2026	2027	2028	2029	2030
GPU Shipments (Mu, total AI)	9	11	12	13	16	20
Power per GPU (W)	2000	2500	3000	3150	3300	3500
Total GPW Power (GW)	18	28	35	41	52	71
800V Adoption (as % of total AI)	0%	2%	9%	23%	50%	80%
Power Semi \$ per kW (GPU power)	\$0	\$55	\$52	\$50	\$47	\$45
<b>Power Semi TAM (\$M)</b>	<b>\$0</b>	<b>\$30</b>	<b>\$164</b>	<b>\$458</b>	<b>\$1,229</b>	<b>\$2,564</b>

***GaN + SiC can be adopted in significant % of this \$2.6B/yr 800V Data Center opportunity***

Note (1) sources:

- Navitas internal analysis, based on company-provided inputs and assumptions.
- Pilz, K, et al (2025). AI's Power Requirements Under Exponential Growth. RAND. [https://www.rand.org/pubs/research\\_reports/RRA3572-1.html](https://www.rand.org/pubs/research_reports/RRA3572-1.html)
- Generative AI 2025 - Computing and AI for Data Center (2025). Yole Group. <https://www.yolegroup.com/product/report/gen-ai-2025---computing-and-ai-for-datacenter/>
- Kim, T. (2025). Nvidia's AI Chip Revenue to More Than Double to \$262 Billion by 2030, Analyst Says. Barrons. <https://www.barrons.com/articles/nvidia-stock-ai-chip-revenue-98dfcfd1>
- Tayyab, R. (2025). Nvidia's May 28 Earnings Could Reset AI Market Expectations, Says Top Analyst. TechCrunch. <https://www.techcrunch.com/nvidia-stock-earnings-preview-may-28-2025/>
- Fox, M. (2025). Nvidia stock could soar 81% if investors recognize its full potential as an AI ecosystem... Business Insider. <https://markets.businessinsider.com/news/stocks/nvidia-stock-price-prediction-ai-ecosystem-potential-fully-realized-2024-4>
- Hambleton, M. (2024). Blackwell platform puts Nvidia in higher realm for cost and energy. Fierce Electronics. <https://www.fierceelectronics.com/ai/blackwell-platform-puts-jensen-higher-realm-cost-and-energy>

## AI Data Center Power Semi TAM (\$M)

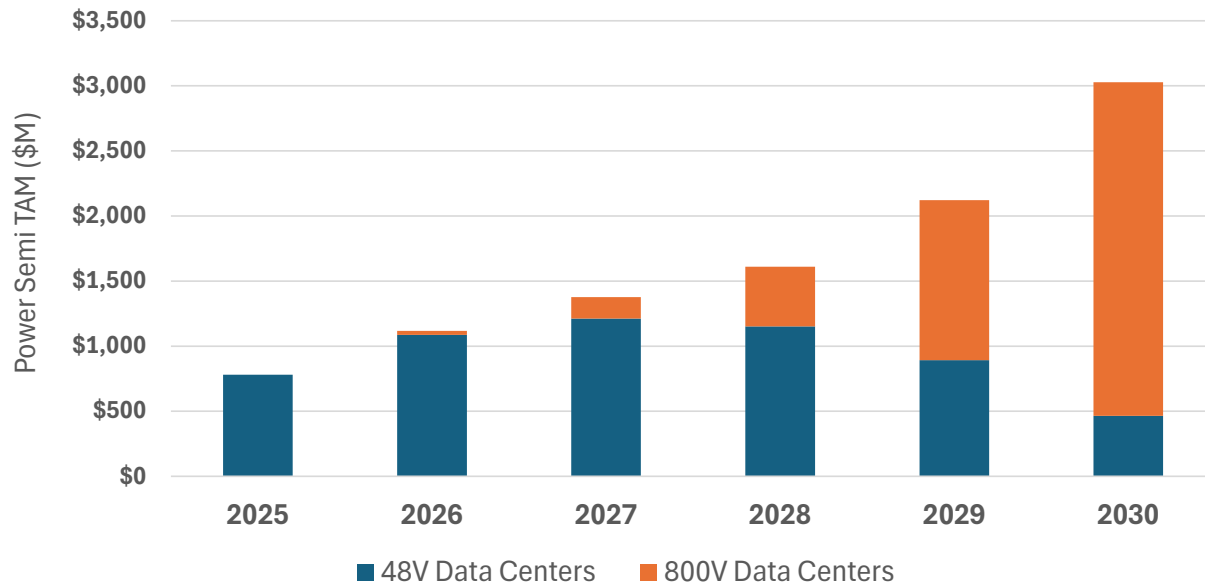

***GaN + SiC can be adopted in significant % of this \$3B/yr total AI Data Center opportunity (48V + 800V)***

Note (1) sources:

- Navitas internal analysis, based on company-provided inputs and assumptions.
- Pilz, K, et al (2025). AI's Power Requirements Under Exponential Growth. RAND. [https://www.rand.org/pubs/research\\_reports/RRA3572-1.html](https://www.rand.org/pubs/research_reports/RRA3572-1.html)
- Generative AI 2025 - Computing and AI for Data Center (2025). Yole Group. <https://www.yolegroup.com/product/report/gen-ai-2025---computing-and-ai-for-datacenter/>
- Kim, T. (2025). Nvidia's AI Chip Revenue to More Than Double to \$262 Billion by 2030, Analyst Says. Barrons. <https://www.barrons.com/articles/nvidia-stock-ai-chip-revenue-98dfccf1>
- Tayyab, R. (2025). Nvidia's May 28 Earnings Could Reset AI Market Expectations, Says Top Analyst. Tech. <https://www.tech.com/nvidia-stock-earnings-preview-may-28-2025/>
- Fox, M. (2025). Nvidia stock could soar 81% if investors recognize its full potential as an AI ecosystem... Business Insider. <https://markets.businessinsider.com/news/stocks/nvidia-stock-price-prediction-ai-ecosystem-potential-fully-realized-2024-4>
- Hambleton, M. (2024). Blackwell platform puts Nvidia in higher realm for cost and energy. Fierce Electronics. <https://www.fiercееlectronics.com/ai/blackwell-platform-puts-jensen-higher-realm-cost-and-energy>



## ***Key Patents in GaN and SiC***

**300+ Patents** issued or pending

Fundamental and broad GaN IC patent portfolio

Fundamental trench-assisted planar SiC patent portfolio

## ***Proprietary Trade Secrets***

Significant highly-protected SiC process know-how

Significant highly-protected GaN IC Process Design Kit (PDK)

## ***Rapid Rate of Innovation***

20 years of GeneSiC innovation leadership

Creators of GaN integrated circuit technology

New generations typically introduced every 18 months



[info@navitassemi.com](mailto:info@navitassemi.com)

[www.navitassemi.com](http://www.navitassemi.com)



## Connect with Navitas



[LinkedIn](#)



[Facebook](#)



[YouTube](#)



[X](#)

